

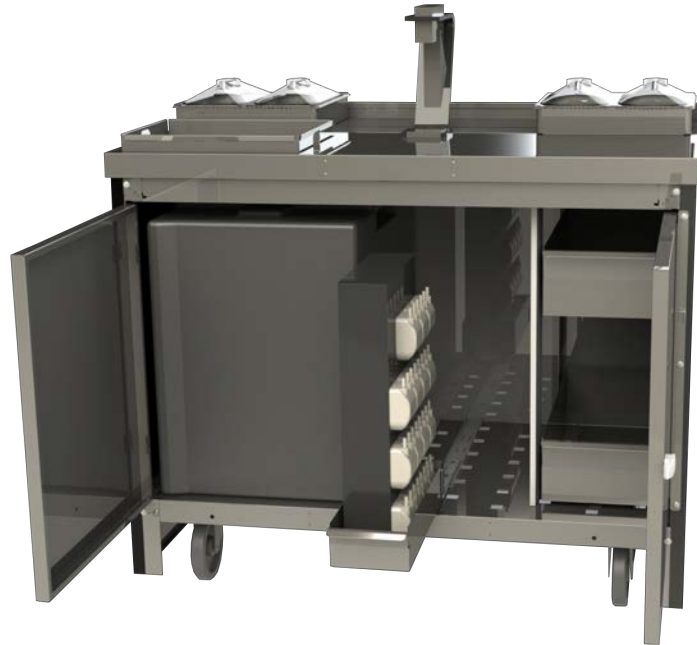

GiG Cart XL



GiG Cart XL is the latest addition to Cocktails Machine product line. It offers the perfect mobile, semi-permanent or permanent solution for complete server station, outdoor spaces, poolside, events, lounges and more. Oversized wheels provide easy maneuverability over all floor coverings. Available as plug-in and battery operated (optional). Integrated Camcarriers® provide hours of insulated storage for ingredients and back up garnishes. Includes:

- 1x GiG Modular (15 lines)
- 1x ice chest
- 4x Garnish trays
- 2x sliding drawers
- 1x 10" Android Tablet
- 1x Tablet Holder
- 1x Cambro Camcarriers®
- Food Grade Silicone Tube
- Bottle Adapters

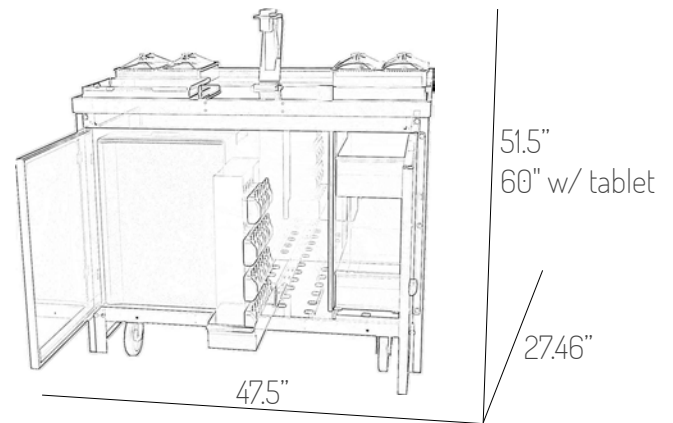

Dimensions w/o tablet (WxDxH)	47.5 x 27.46 x 51.5in.
Dimensions with tablet (WxDxH)	47.5 x 27.46 x 60in.
Net Weight	230 lbs.
Voltage	12V
Max. Absorbed Power:	75W
Power:	110/220V 50-60hz
Power Cord:	US
Item number	CMCARTXL15



(customizable logo on demand)